

Renderplas Ltd

Number 2
70-72 High Street
Bewdley
Worcestershire DY12 2DJ
Tel: 01299 888333
e-mail: info@renderplas.co.uk
website: www.renderplas.co.uk



Agrément Certificate
11/4823
Product Sheet 2

RENDERPLAS RENDER BEADS

RENDERPLAS PVC BEADS

This Agrément Certificate Product Sheet⁽¹⁾ relates to Renderplas PVC Beads, a range of coloured PVC-U extrusions for use with render on new or existing buildings.

(1) Hereinafter referred to as 'Certificate'.

CERTIFICATION INCLUDES:

- factors relating to compliance with Building Regulations where applicable
- factors relating to additional non-regulatory information where applicable
- independently verified technical specification
- assessment criteria and technical investigations
- design considerations
- installation guidance
- regular surveillance of production
- formal three-yearly review.



KEY FACTORS ASSESSED

Structural stability — the products provide satisfactory fixing and support to the applied render and adequate resistance to mechanical damage (see section 6).

Performance in relation to fire — the products would not be classified as 'non-combustible' when tested in accordance with BS 476-4 : 1970 or BS EN 13501-1 : 2007 but, in the opinion of the BBA, will not introduce an additional hazard in respect of the behaviour in fire of the rendered surface (see section 7).

Durability — the products are formed from durable materials and, while there will be some colour loss, will perform adequately as a support for external rendering for a period of at least 25 years (see section 9).



The BBA has awarded this Certificate to the company named above for the products described herein. These products have been assessed by the BBA as being fit for their intended use provided they are installed, used and maintained as set out in this Certificate.

On behalf of the British Board of Agrément

John Albon — Head of Approvals
Construction Products

Claire Curtis-Thomas
Chief Executive

Date of Third issue: 30 May 2017

Originally certificated on 21 March 2011

Certificate amended on 16 May 2019 to include Regulation 7(2) for England and associated text.

Certificate amended on 18 May 2020 to include new regulatory guidance for fire in Wales.

The BBA is a UKAS accredited certification body – Number 113.

The schedule of the current scope of accreditation for product certification is available in pdf format via the UKAS link on the BBA website at www.bbacerts.co.uk

Readers MUST check the validity and latest issue number of this Agrément Certificate by either referring to the BBA website or contacting the BBA directly.

Any photographs are for illustrative purposes only, do not constitute advice and should not be relied upon.

British Board of Agrément

Bucknalls Lane
Watford
Herts WD25 9BA

©2019

tel: 01923 665300
clientservices@bbacerts.co.uk
www.bbacerts.co.uk

Regulations

In the opinion of the BBA, Renderplas PVC Beads, if installed, used and maintained in accordance with this Certificate, can satisfy or contribute to satisfying the relevant requirements of the following Building Regulations (the presence of a UK map indicates that the subject is related to the Building Regulations in the region or regions of the UK depicted):



The Building Regulations 2010 (England and Wales) (as amended)

Requirement:	B4(1)	External fire spread
Comment:		The products will not adversely affect the fire properties of a wall in which they are incorporated. See section 7.1 of this Certificate.
Regulation:	7(1)	Materials and workmanship
Comment:		The products are acceptable. See section 9.1 and the <i>Installation</i> part of this Certificate.
Regulation:	7(2)	Materials and workmanship
Comment:		The products are restricted in some cases by this Regulation. See section 7 of this Certificate.



The Building (Scotland) Regulations 2004 (as amended)

Regulation:	8(1)	Durability, workmanship and fitness of materials
Comment:		The products can contribute to a construction satisfying this Regulation. See section 9.1 and the <i>Installation</i> part of this Certificate.
Regulation:	9	Building standards applicable to construction
Standard:	2.6	Spread to neighbouring buildings
Standard:	2.7	Spread on external walls
Comment:		The products are not classified as 'non-combustible' and are therefore restricted by these Standards, with reference to clauses 2.6.4 ⁽¹⁾⁽²⁾ , 2.6.5 ⁽¹⁾ , 2.6.6 ⁽²⁾ and 2.7.1 ⁽¹⁾⁽²⁾ . See section 7 of this Certificate.
Standard:	7.1(a)(b)	Statement of sustainability
Comment:		The products can contribute to meeting the relevant requirements of Regulation 9, Standards 1 to 6 and therefore will contribute to a construction meeting a bronze level of sustainability as defined in this Standard.
Regulation:	12	Building standards applicable to conversions
Comment:		All comments given for the products under Regulation 9, Standards 1 to 6 also apply to this Regulation, with reference to clause 0.12.1 ⁽¹⁾⁽²⁾ and Schedule 6 ⁽¹⁾⁽²⁾ . (1) Technical Handbook (Domestic). (2) Technical Handbook (Non-Domestic).



The Building Regulations (Northern Ireland) 2012 (as amended)

Regulation:	23(i)(iii)(b)(i)	Fitness of materials and workmanship
Comment:		The products are acceptable. See section 9.1 and the <i>Installation</i> part of this Certificate.
Regulation:	36(a)	External fire spread
Comment:		The products will not adversely affect the fire properties of a wall in which they are incorporated. See section 7 of this Certificate.

Construction (Design and Management) Regulations 2015

Construction (Design and Management) Regulations (Northern Ireland) 2016

Information in this Certificate may assist the client, designer (including Principal Designer) and contractor (including Principal Contractor) to address their obligations under these Regulations.

See section: 3 *Delivery and site handling* (3.1) of this Certificate.

Technical Specification

1 Description

1.1 Renderplas PVC Beads are PVC-U extrusions designed for use with render in external applications. The back plates incorporate hexagonal holes and a ribbed surface, providing a key for the render.

1.2 The available types (see Figure 1) are:

- Bellcast beads — to form a reinforced stop (or bellcasting) at the lower edge of external rendering
- Corner beads — to form a reinforced arris in external rendering
- Movement joint MJ — to form standard joints and accommodate movement of up to ± 2.5 mm for standard joints
- Movement joint MJW and MJX — to form wide joints and accommodate movement of up to ± 1.5 mm in external rendering
- Stop beads — for forming reinforced edges of external renderings.

Figure 1 Renderplas PVC Beads

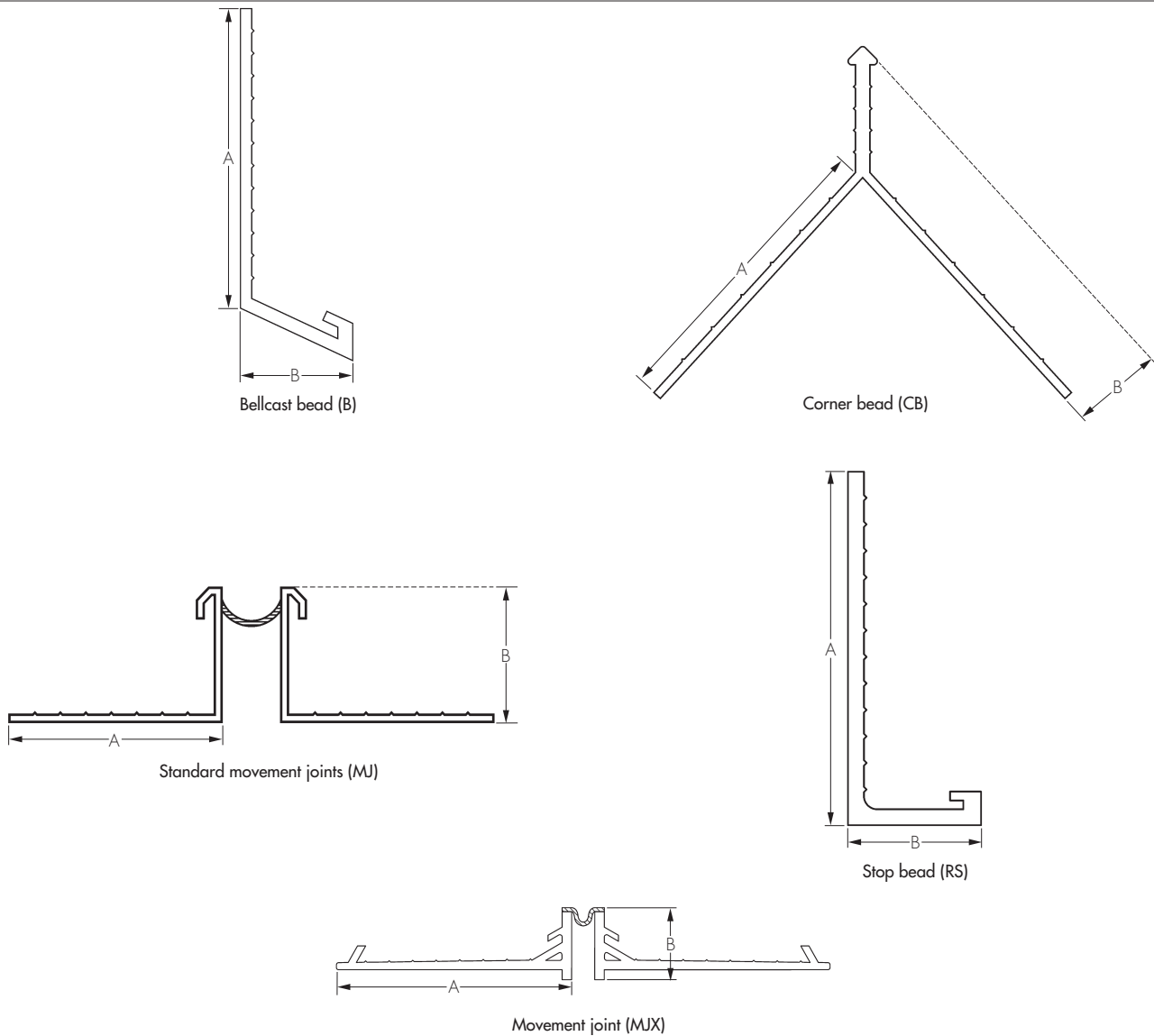

Code	Size (mm)	Render depth (mm)	A (mm)	B (mm)	Wall thickness (mm)	Hexagonal punch pattern
B10	10	4-10	25	10	1.2	1
BC10	10	4-12	40	10	1.5	2
B15	15	10-17	40	15	1.5	2
B20	20	13-22	40	20	1.5	2
CB2	2	2-3	23	2	1.2	1
CB4	4	4-6	40	4	1.5	2
CB6	6	6-8	40	6	1.5	2
CB8	8	8-10	40	8	1.5	2
CB10	10	10-12	40	10	1.5	2
CB15	15	14-17	40	15	1.5	2
CB20	20	18-22	40	20	1.2	2
MJ4	4	4-6	25	4	0.8	1
MJ6	6	6-8	25	6	0.8	1
MJ10	10	10-12	25	10	0.8	1
MJ15	15	14-17	25	15	0.8	1
MJ20	20	18-22	25	20	0.8	1
MJW6	6	6-8	50	6	1.2	2
MJW10	10	10-12	50	10	1.2	2
MJX15	15	15-17	50	15	1.5	2
RS4	4	4-6	40	4	1.2	2
RS6	6	6-8	40	6	1.2	2
RS10	10	10-12	40	10	1.5	2
RS15	15	15-17	40	15	1.5	2
RS20	20	20-22	40	20	1.5	2

1.3 The profiles are available in the following range of colours⁽¹⁾:

- White
- Wheat
- Slate
- Ivory
- Peach
- Dove
- Brick
- Salmon
- Sky
- Terracotta
- Maize
- Willow.

(1) CB20, MJ6, MJ10, MJ15 are stocked in White and Ivory. B10, RS4, CB2, CB4, CB8, MJ4 and MJ20 are only stocked in White; other colours are available from the Certificate holder subject to a minimum order size.

1.4 The profiles are supplied in 2.5 m lengths.

2 Manufacture

2.1 The products are manufactured by extrusion from recycled PVC-U.

2.2 As part of the assessment and ongoing surveillance of product quality, the BBA has:

- agreed with the manufacturer the quality control procedures and product testing to be undertaken
- assessed and agreed the quality control operated over batches of incoming materials
- monitored the production process and verified that it is in accordance with the documented process
- evaluated the process for management of nonconformities
- checked that equipment has been properly tested and calibrated
- undertaken to carry out the above measures on a regular basis through a surveillance process, to verify that the specifications and quality control operated by the manufacturer are being maintained.

2.3 The management system of the manufacturer has been assessed and registered as meeting the requirements of BS EN ISO 9001 : 2008 by BSI (Certificates FM 595640 and FM 508850).

3 Delivery and site handling

3.1 Renderplas PVC Beads are delivered in cardboard boxes or tubes. Pack sizes and weights are detailed in Table 1. Each pack has a label bearing the Certificate holder's name, product name and the BBA logo incorporating the number of this Certificate.

Product	Code	Number of beads per pack	Weight per pack (kg)
Bellcast bead	B10	25	4.5
	BC10	25	6.7
	B15	25	11.1
	B20	25	12.9
Corner bead	CB2	25	4.4
	CB4	25	11.7
	CB6	25	12.0
	CB8	25	12.1
	CB10	25	12.3
	CB15	25	13.7
	CB20	6	3.5
Movement joints bead	MJ4	25	5.3
	MJ6	25	5.9
	MJ10	25	7.1
	MJ15	25	7.3
	MJ20	25	7.6
	MJW6	6	3.5
	MJW10	6	3.6
	MJX15	6	6.4
Stop bead	RS4	25	4.4
	RS6	25	4.7
	RS10	25	7.7
	RS15	25	10.0
	RS20	25	8.4

3.2 To prevent distortion, packs of profiles should be stored straight, away from direct sunlight and excessive heat. When stored horizontally, they must be supported along their entire length.

Assessment and Technical Investigations

The following is a summary of the assessment and technical investigations carried out on Renderplas PVC Beads.

Design Considerations

4 Use

Renderplas PVC Beads are for use with external rendering on walls of masonry, dense concrete or timber-frame construction.

5 Practicability of installation

The products are designed to be installed by a competent general builder experienced in external rendering.

6 Structural stability

6.1 The profiles provide adequate fixing and support to the applied render.

6.2 The profiles have adequate resistance to mechanical damage, but can be damaged by severe impacts.

7 Performance in relation to fire



The profiles would not be classified as 'non-combustible' when tested in accordance with BS 476-4 : 1970 or BS EN 13501-1 : 2007 but in the opinion of the BBA, will not introduce an additional hazard in respect of the behaviour in fire of the rendered surface.

8 Maintenance

As the products are used in a wall structure and have suitable durability, maintenance is generally not required.

9 Durability



9.1 The products are formed from durable materials and will perform adequately as a support for external rendering for a period of at least 25 years.

9.2 There will be some loss of colour over this period. This will vary depending on the colour chosen, but will not be excessive and will be consistent over any one aspect faced.

Installation

10 General

10.1 Renderplas PVC Beads can be cut to length on site using normal hand tools, such as a fine-toothed saw or tin snips.

10.2 Any irregularities in the substrate must be dubbed out with render and allowed to set hard prior to installation of the products.

11 Procedure

11.1 The correct size of profile should be selected for the particular application (see Figure 1) and cut to length.

11.2 The profile is levelled to ensure that it is plumb, and is fixed by pressing it firmly into a continuous bed of render which has been previously applied to the substrate. Galvanized or stainless steel fixings can be used to provide temporary support to assist in levelling the product. Where appropriate, temporary fixings should be removed prior to rendering.

11.3 Render is applied over the bead in a conventional manner, ensuring that it is fully compacted and placed to the edge of the nosing.

11.4 The external rendering must be applied in accordance with BS EN 13914-1 : 2016 and the render manufacturer's instructions.

11.5 When the render requires a scraped or textured finish, care must be taken not to damage the flexible membrane of the movement joint.

Technical Investigations

12 Tests

Tests were carried out and the results assessed to determine:

- impact resistance
- heat ageing characteristics
- resistance to artificial weathering
- pull-out resistance of fixings

- pull-out resistance from render
- effectiveness of the movement joint.

13 Investigations

13.1 The manufacturing process was evaluated, including the methods adopted for quality control, and details were obtained of the quality and composition of the materials used.

13.2 A postal user survey was carried out to assess the products' performance in use.

13.3 Visits were made to a site to witness the installation of the products.

Bibliography

BS 476-4 : 1970 *Fire tests on building materials and structures — Non-combustibility test for materials*

BS EN 13501-1 : 2007 + A1 : 2009 *Fire classification of construction products and building elements — Classification using test data from reaction to fire tests*

BS EN 13914-1 : 2016 *Design, preparation and application of external rendering and internal plastering — External rendering*

BS EN ISO 9001 : 2008 *Quality management systems — Requirements*

Conditions of Certification

14 Conditions

14.1 This Certificate:

- relates only to the product/system that is named and described on the front page
- is issued only to the company, firm, organisation or person named on the front page — no other company, firm, organisation or person may hold or claim that this Certificate has been issued to them
- is valid only within the UK
- has to be read, considered and used as a whole document — it may be misleading and will be incomplete to be selective
- is copyright of the BBA
- is subject to English Law.

14.2 Publications, documents, specifications, legislation, regulations, standards and the like referenced in this Certificate are those that were current and/or deemed relevant by the BBA at the date of issue or reissue of this Certificate.

14.3 This Certificate will remain valid for an unlimited period provided that the product/system and its manufacture and/or fabrication, including all related and relevant parts and processes thereof:

- are maintained at or above the levels which have been assessed and found to be satisfactory by the BBA
- continue to be checked as and when deemed appropriate by the BBA under arrangements that it will determine
- are reviewed by the BBA as and when it considers appropriate.

14.4 The BBA has used due skill, care and diligence in preparing this Certificate, but no warranty is provided.

14.5 In issuing this Certificate, the BBA is not responsible and is excluded from any liability to any company, firm, organisation or person, for any matters arising directly or indirectly from:

- the presence or absence of any patent, intellectual property or similar rights subsisting in the product/system or any other product/system
- the right of the Certificate holder to manufacture, supply, install, maintain or market the product/system
- actual installations of the product/system, including their nature, design, methods, performance, workmanship and maintenance
- any works and constructions in which the product/system is installed, including their nature, design, methods, performance, workmanship and maintenance
- any loss or damage, including personal injury, howsoever caused by the product/system, including its manufacture, supply, installation, use, maintenance and removal
- any claims by the manufacturer relating to CE marking.

14.6 Any information relating to the manufacture, supply, installation, use, maintenance and removal of this product/system which is contained or referred to in this Certificate is the minimum required to be met when the product/system is manufactured, supplied, installed, used, maintained and removed. It does not purport in any way to restate the requirements of the Health and Safety at Work etc. Act 1974, or of any other statutory, common law or other duty which may exist at the date of issue or reissue of this Certificate; nor is conformity with such information to be taken as satisfying the requirements of the 1974 Act or of any statutory, common law or other duty of care.

British Board of Agrément

Bucknalls Lane
Watford
Herts WD25 9BA

©2019

tel: 01923 665300
clientservices@bbacerts.co.uk
www.bbacerts.co.uk